

# Approach to Interconnect Existing Industrial Automation Systems with the Industrial Internet

Alexander Faul, Nasser Jazdi, Michael Weyrich  
Institute of Industrial Automation and Software Engineering  
University of Stuttgart  
Stuttgart, Germany  
ias@ias.uni-stuttgart.de

**Abstract** — In this document we describe an approach to interconnect existing industrial automation systems with cooperation networks, like the internet of things, even if the industrial automation system uses a different communication protocol. To realize this, we have developed the concept of connector which provides system-dependent interfaces for different industrial automation and a universal interface for the cooperation network. Between these interfaces the messages are processed and translated by services, which act as a representation of the industrial automation system.

**Keywords** — industry 4.0; interconnection; automated systems; smart gateway; connector; industrial automation systems

## I. INTRODUCTION

Very less invention, with the exception of fire and wheel, had influenced our live on such a major magnitude like the Internet. Especially in the last 10 years, its influence got stronger through the rise of social media and smartphones and will get even bigger through the increasing number of web-enabled automation systems and the Internet of Things (IoT). This trend allows the systems to provide current data about its state and sensor values in an easy way. These information are used to create new business models, which range from remote control of the systems to the deployment of updates and remote diagnosis [1]. The German government identified this already in the year 2011 and started with “Industrie 4.0” an initiative with the purpose to coordinate and speed up the development of interconnected industrial production systems to ensure the competitiveness of Germany in the industrial domain [2].

A problem, which many of the solutions of the “Industrie 4.0” initiative have, is that they use common internet technologies to interconnect the industrial automation systems. These technologies are not supported by the great amount of existing industrial automation systems. These systems cannot be replaced easily, because of economic considerations. Therefore are concepts necessary, which enables existing systems to handle the internet technologies used to interconnect them and to participate in “Industrie 4.0”. One concept to enhance existing industrial automation systems for “Industrie 4.0” is described in this paper.

## II. STATE OF THE ART

As shown in the former chapter, the interconnection and interaction of different industrial automation systems is an

important development in the domain of industrial automation. Several projects, which are described in this chapter, try to realize the communication between different automation systems as base of the interconnection.

### A. OSGI framework

The OSGI-Alliance, former known as Open Service Gateway Initiative, develops the so-called OSGI framework. The framework provides a hardware independent software platform based on the programming language java. This platform allows the development of software components, which are combined to applications. The OSGI framework realizes the hardware independence of the interfaces by abstracting them. Therefore an abstraction component for each type of interface is needed. This allows the usage of the framework in the interconnection and controlling of intelligent systems. Especially in the area of building automation runs the software not directly on the automation system. Instead, it runs on a residential gateway, which provides the data [3].

### B. Arrowhead

The goal of the arrowhead project is to create a framework for the interaction of automation systems, which are traditionally realized with different technologies. The project hereby aims the domains production, intelligent buildings and infrastructure, electro mobility, energy generation and energy market place. The framework is based on a service-oriented architecture (SOA) which allows the interaction of different systems. With this concept, it is also possible to integrate existing automation systems, if they have services like SOA [4].

### C. ETSI SmartM2M

The European Telecommunications Standards Institute (ETSI) has created through there technical committee SmartM2M a standardized platform for the internet of things and the machine to machine communication (M2M) [5]. Goal of this platform is to provide interoperable and cost efficient solutions. Therefore it provides concepts to interconnect automation systems, mainly based on mobile communication networks.

### D. Reference architectures

A reference architecture is an architecture, which is created to be a template for real architectures and therefore simplifies their development. There are many reference architectures for the cooperation of automation systems cf. [6]. Some of them are described here in more detail.

#### 1) Industrial Reference Architecture (IRA)

The Industrial Internet Consortium (IIC) has created with the IIRA [7] a reference architecture for the dynamic interconnection of industrial automation systems. This architecture consists of four layers, which cover the whole area from the business processes to the implementation of the systems. For the integration of automation systems in the industrial internet system, the architecture provides edge gateways. These gateways abstract a local network with actors and sensors and provide the access to them.

2) *Internet of things architecture (IoT-A)*

A consortium of science and industry develops the internet of things architecture [8]. The architecture consists of two parts. One part is a reference model, which is used to clarify the terms. The other part is the architecture itself, which describes the basic parts of an IoT system, like the physical and virtual entity. It also contains guidelines about handling conflicting requirements.

3) *Reference Architecture Model Industry 4.0 (RAMI4.0)*

The German Institutions VDI and ZVEI defined the RAMI4.0 [9]. This reference Architecture consists of a three dimensional representation of the aspects, which have to be considered at defining an industry 4.0 system. Other than the IIRA and the IoT-A provides the RAMI4.0 less information on how to solve implementation problems. The three dimensional representation is instead better to discuss ideas and compare different solutions.

The existing approaches address either the development of new systems or are domain specific solutions with a low rate of reusability respectively portability. Therefore a more universal approach is needed to handle the various industrial automation systems.

III. CONCEPT OF THE I4.0-CONNECTOR

Goal of the concept is the extension of existing industrial automation systems, without modifying them, so that these can participate in dynamic cooperation scenarios. Dynamic cooperation is the base of the Industrial Internet and the Internet of Things. To reach that goal, the concept proposes a connector, which represent the industrial automation system in the dynamic cooperation.

The connector proposed by the concept is named I4.0 connector and consist of four major parts, the interface to the industrial automation system, the service management and the

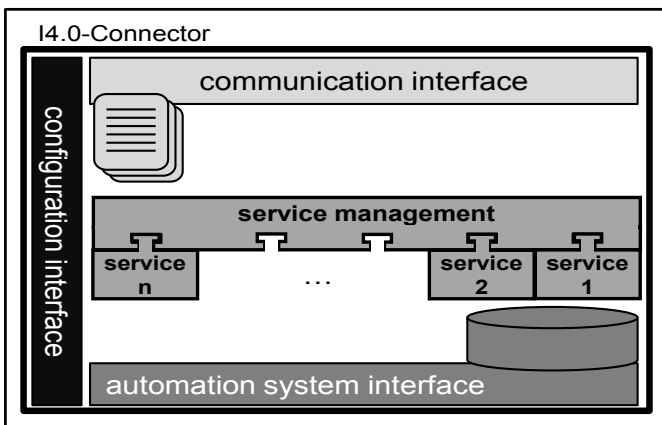

Fig. 1: Parts of the I4.0-Connector

services, the interface for the cooperation and the configuration interface. These major parts are shown in Fig. 1 and explained in more details in the following paragraphs.

Fig. 2 shows the interconnection of the industrial automation system on the left side with the cooperation network on the right side by the I4.0 connector in the middle. The interfaces are shown as ISO-OSI protocol stacks, where the implemented layers are shown in gray color. For the connection, it is not necessary that the industrial automation system and the cooperation network use the same protocol, because the services of the I4.0 connector, on layer 7 of the ISO-OSI stack, translate the messages from one protocol into another protocol. With this functionality, the services define the behavior of the connector and the represented industrial automation system in the cooperation network.

A. *automation system interface*

The automation system interface provides the connection of the connector with the industrial automation system. Therefore an existing interface of the industrial automation system is used to avoid changes. The fact, that industrial automation systems use a variety of different protocols and semantics makes it necessary, that the interface is very flexible.

To realize this flexibility of the interface, it consists of two parts. One part is the interpreter, which realize the physical constraints (e.g. voltage levels) of the used communication protocol. The other part is the model of the interface, consisting of the protocol description and the used semantic. The interpreter to analyze and synthesize messages to and from the industrial automation system uses this information. To make the creation of this interface model easier, the concept provides a basic description in an ontology. This basic description, shown in Fig. 3, is the starting point for the analysis of the information by the interpreter and has to be extended according to the used communication protocol and the semantic of the real interface, like pictured in Fig. 4.

The basic structure consists of multiple classes. The class interface represent the universal starting point for the analysis of the structure. The class message represent messages which can

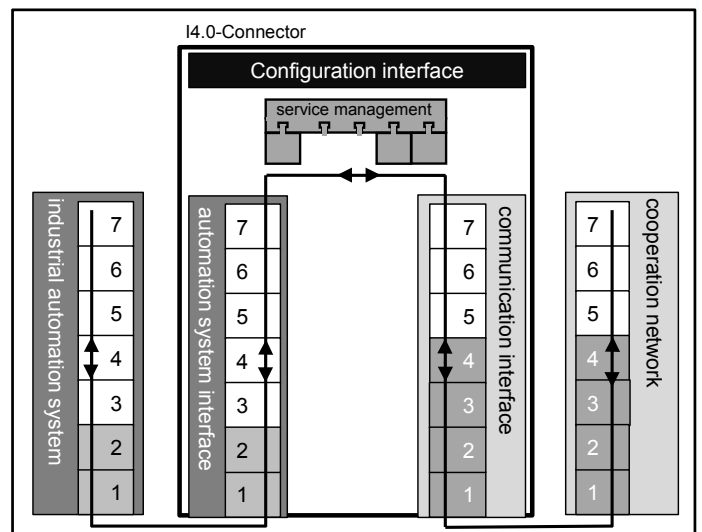

Fig. 2: The connection of two networks with different communication protocols

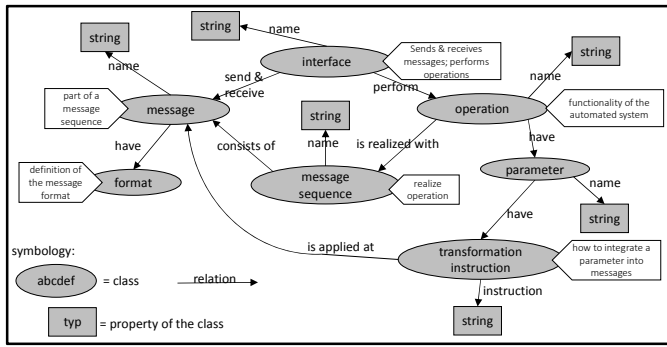

Fig. 3: Basic structure of the interface description in the ontology

be send by the interface. The operations which can be performed by the interface are modeled in the class operations. To realize an operation a sequence of messages, represented by the class message sequence has to be send by the interface. The possible parameters of the operations are represented by the class parameter. The last class of the basic structure are the transformation instruction, which defines how the parameter has to be integrated into the messages of the message sequence.

Based on the extended structure, instances of the classes are created. These instances represent, like objects in the object-oriented programming, individual values of the classes.

### B. Communication interface

The second interface of the I4.0 connector provides the connection to the cooperation network. The challenge for this is, that no standard protocol for the cooperation network exists. To encounter this, the concept defines this interface as exchangeable component, where each instance of the component realizes a certain protocol. To ensure the exchangeability, the interface realizes the protocol dependent parameters and transfers the payload to the services. Part of the protocol dependent parameters are the connection parameters, like IP address and port number, name and connection

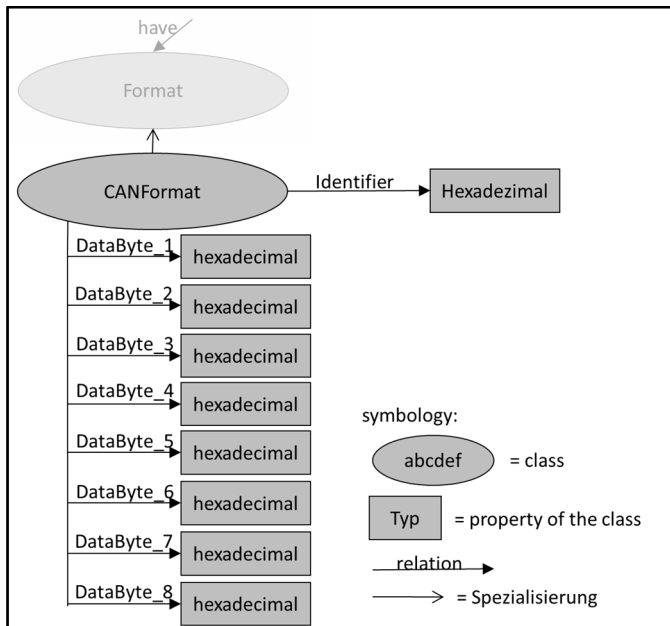

Fig. 4: Specialization of the basic description structure by the definition of the CAN format

information of special services, like discovery server. To access this information, the components provide a special interface, which makes the services independent from detailed knowledge of the cooperation network.

### C. Service management and service

The connection between the two interfaces described in the former paragraphs is provided by the service management and the services itself.

The service management provides a uniform interface for the services and routes the messages from the services to the interfaces and vice versa. The service management gets the needed information for the routing from the registration of services. This registration also enables the management to deactivate single services and to process messages to not existing or deactivated services. The management also provides the services with additional protocol independent information.

The services, which are connected to and registered at the service management, define the behavior of the I4.0 connector and thereby of the represented industrial automation system. The services are, because of the abstraction of the communication by both interfaces and the routing from the service management, protocol independent. This makes them exchangeable and therefore reusable and the behavior of the I4.0 connector adaptable.

### D. Configuration interface

The flexibility of the concept, regarding the different communication protocols, makes it necessary that the I4.0 connector can be adapted at run time. For this the concept provides the configuration interface. With that interface it is possible, to change certain parameters like communication parameters and the addresses of special services.

## IV. REALISATION OF THE CONCEPT

The introduced concept was realized on different model processes. One of the model processes was a gastronomic coffee machine from the company WMF. This coffee machine has an internal CAN-Bus to coordinate the separate parts. The concept was realized on a normal PC with the Operating System Windows 7 and a PCAN USB can interface to connect to the coffee machine. As programming language was Java used, while the ontology was developed with the tool Protégé and then included in the java application. Fig. 5 shows a cutout of the instances of the implemented ontology for the coffee machine consisting among other things of the interface, one operation and two detailed messages out of the message sequence for the operation. Additional to the concept, a small user interface was realized, which provides the functionality to parse XML-files and perform the actions defined in them.

Another realization of the concept was a modular production system for cars made of Lego bricks. The production system consists of individual processing units, which are controlled by a Raspberry Pi. The concept was realized based on software agents and programmed with the Java agent framework JADE. The Agent Communication Language (ACL) is used in the production system as communication protocol between the

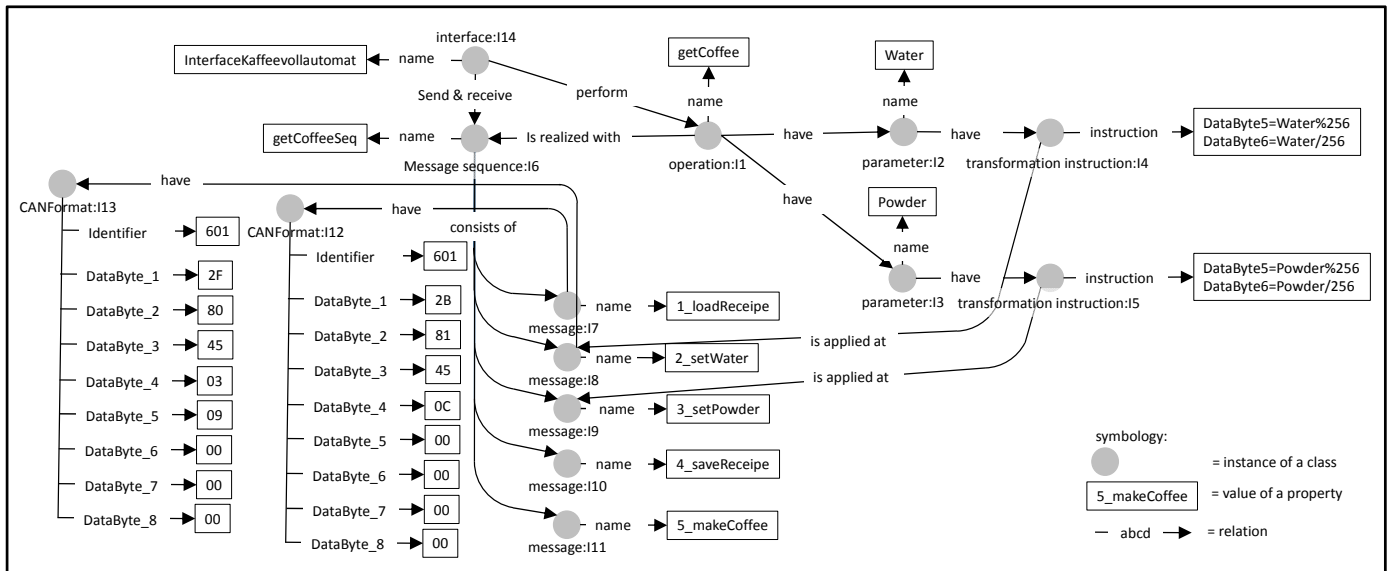

Fig. 5: Cutout of the instances from the interface to an automated coffee machine

processing units. The services of the I4.0 connectors are implemented as behaviors of the software agents, while the control of the processing units is realized as scripts in the language python.

## V. EVALUATION

The proposed concept is evaluated with different industrial automation systems. This systems are the gastronomic coffee machine described in the former chapter, a modular production system which produce Lego model cars and a simulated model process. The first two industrial automation systems are located at the Institute of Industrial Automation and Software Engineering in Stuttgart, Germany, while the last one is located at the Federal University of Amazonas in Manaus, Brazil.

During the implementation and evaluation some disadvantages of the original concept where found and resolved. For example were no parameters for the operations modeled in the ontology possible. That resulted in many different operations for a similar task, e.g. the production of coffee. Another drawback, and the cause to introduce the configuration interface, was discovered as a new discovery server were introduced in the modular production system. Without this interface each I4.0 connector has to be rebuild with the new information.

The evaluation showed that the proposed concept could be used and realized for different industrial automation systems with minimal effort.

## VI. CONCLUSION AND OUTLOOK

With the concept described in this paper it is possible to realize extensions for existing industrial automation systems. These extensions connect the industrial automation system with a cooperation network to enable their participations in scenarios of the Internet of Things, Industrial Internet and "Industrie 4.0". To evaluate the concept it was realized for three different industrial automation systems. The results of these realizations show that the approach is effective and can be easily used for different industrial automation systems.

To increase the acceptance of the concept by the user it is important that this does not have to deal with the details of programming. Therefore a framework is actually under development, which allows the user to realize the I4.0 connector with minimal effort. The framework reaches this by supporting the user with prefabricated components, and defined interfaces.

## REFERENCES

- [1] N. JAZDI, "CYBER PHYSICAL SYSTEMS IN THE CONTEXT OF INDUSTRY 4.0," IN AUTOMATION, QUALITY AND TESTING, ROBOTICS, 2014 IEEE INTERNATIONAL CONFERENCE ON, 2014, PP. 1–4.
- [2] BUNDESMINISTERIUM FÜR BILDUNG UND FORSCHUNG, *ZUKUNFTSBILD „INDUSTRIE 4.0“*. AVAILABLE: [HTTP://WWW.BMBF.DE/PUB/BRD/ZUKUNFTSBILD\\_INDUSTRIE\\_40.PDF](http://www.bmbf.de/pub/BRD/ZUKUNFTSBILD_INDUSTRIE_40.PDF) (2015, FEB. 02).
- [3] OSGI ALLIANCE, *OSGI CORE*. AVAILABLE: [HTTPS://OSGI.ORG/DOWNLOAD/R6/OSGI.CORE-6.0.0.PDF](https://osgi.org/download/r6/osgi.core-6.0.0.pdf) (2016, APR. 11).
- [4] C. LE PAPE, *DELIVERABLE D1.3 OF WORK PACKAGE 1: GENERATION 1 DEMONSTRATIONS, CONCLUSIONS, AND PERSPECIVES*. AVAILABLE: [HTTP://WWW.ARROWHEAD.EU/WP-CONTENT/UPLOADS/2013/03/ARROWHEAD-DELIVERABLE-PILOT-WP1-D1.3-v1.4.PDF](http://www.arrowhead.eu/wp-content/uploads/2013/03/ARROWHEAD-DELIVERABLE-PILOT-WP1-D1.3-v1.4.pdf) (2016, APR. 11).
- [5] ETSI TECHNICAL COMMITTEE MACHINE-TO-MACHINE, *MACHINE - TO - MACHINE COMMUNICATIONS (M2M); FUNCTIONAL ARCHITECTURE*. AVAILABLE: [HTTP://WWW.ETSI.ORG/DELIVER/ETSI\\_TS/102600\\_102699/102690/02.01.01\\_60/TS\\_102690V020101P.PDF](http://www.etsi.org/deliver/etsi_ts/102600_102699/102690/02.01.01_60/ts_102690v020101p.pdf) (2016, APR. 11).
- [6] M. WEYRICH AND C. EBERT, "REFERENCE ARCHITECTURES FOR THE INTERNET OF THINGS," *IEEE SOFTW*, VOL. 33, NO. 1, PP. 112–116, 2016.
- [7] S.-W. LIN AND B. MILLER ET AL, *INDUSTRIAL INTERNET REFERENCE ARCHITECTURE - IIRA-1-7-AJS.PDF*. AVAILABLE: [HTTP://WWW.IICONSORTIUM.ORG/IIRA-1-7-AJS.PDF](http://www.iiconsortium.org/IIRA-1-7-AJS.PDF) (2015, OCT. 15).
- [8] A. NETTSTRÄTER, *INTERNET-OF-THINGS ARCHITECTURE: DELIVERABLE D1.3 - UPDATED REFERENCE MODEL FOR IOT V1.5*. AVAILABLE: [HTTP://WWW.IOT-A.EU/ARM/D1.3/AT\\_DOWNLOAD/FILE](http://www.iot-a.eu/arm/d1.3/at_download/file) (2016, APR. 11).
- [9] P. ADOLPHS AND H. BEDENBENDER ET AL, *STATUSREPORT: REFERENZARCHITEKTURMODELL INDUSTRIE 4.0 (RAMI4.0)*. AVAILABLE: [HTTPS://WWW.VDI.DE/FILEADMIN/USER\\_UPLOAD/VDI-GMA\\_STATUSREPORT\\_REFERENZARCHITEKTURMODELL-INDUSTRIE40.PDF](https://www.vdi.de/fileadmin/user_upload/VDI-GMA_STATUSREPORT_REFERENZARCHITEKTURMODELL-INDUSTRIE40.PDF) (2016, APR. 11)